

Manish Agrawal and Grandon Gill

Infinity Computer Solutions: Ramping up¹

A professional is expensive, but can I really afford an amateur on this tight ship?

Grant Baxley pondered this question as he considered how he should go about hiring new staff. A self-made entrepreneur, he had founded Infinity Computer Solutions to provide IT services to small and medium sized businesses in the Tampa Bay area. Recent product introductions by the company had received good market acceptance and he was getting opportunities to sell his services to larger clients. He now found himself thinking about the things he needed to accomplish in order to take his business to the next level. The market was there, he thought. What was missing was the skill set required to take advantage of the available opportunities.

As a small business owner and operator, Grant found that juggling strategic and operational issues at the same time was preventing him from prioritizing his attention to the issues that would help him grow his company. He needed to find ways to leverage his time better so that he could focus all his energies on meeting new clients, understanding their needs and customizing his offerings and pricing for each client.

Grant realized that he had a range of options. At one extreme, he could “throw money at the problem,” by hiring professionals to take care of business functions such as marketing and accounting. Solutions following this principle would allow him to choose among the best of breed and ensure high levels of professionalism within the company. At the other extreme, he could operate on a shoestring budget, hiring students or other less-experienced (and therefore much less expensive) people to take care of some routine activities, so he could focus on client-centric activities. This would conserve cash-flow, but leave him with more day-to-day responsibilities. Between these extremes, he saw the following options:

1. Seek additional funding to ramp up employees and marketing (hire professionals already in the industry that are currently unemployed due to downsizing.
2. Hire a recruiting agency to select professionals he could hire
3. Canvass his network of contacts to identify professionals he could hire
4. Post job ads on inexpensive or free sites such as Craig’s List
5. Hire a retiree and train him/ her to perform routine work and simple technical maintenance
6. Hire a student and train him/ her in routine office work
7. Continue as before, just work harder until the company had acquired a medium-long term client, assuring a steady cash flow, and then look for new hires

Like most decisions he had to make, Grant knew that this decision too needed to be made quickly. There was a trade show coming up in Orlando in 6 weeks and he wanted to make sure he had wrapped up the changes before the show.

¹ Copyright © 2011, Manish Agrawal and Grandon Gill. This case was prepared for the purpose of class discussion, and not to illustrate the effective or ineffective handling of an administrative situation. Permission is granted to copy and distribute this case for non-commercial purposes, in both printed and electronic formats. This material is based upon work supported by the National Science Foundation under Grant No. 1043919.

The IT services industry

The IT services industry can be broken into two segments: hosting and support services. The hosting segment of the market includes sites and applications that reside on 3rd party servers. Support services include help desk and training, installation, maintenance and repair, and security-related activities. These may involve an organization's own hardware, or may also relate to hosted applications. More recently, improvements in communications and virtualization technologies have produced a third type of service—cloud computing—that combines elements of the first two. Each market segment has its own structure.

Hosting Services

Hosting services provide customers with broad range of options. At the low end, they may consist of serving up a client's basic web site. Such hosting can be very inexpensive—even free (if the client does not mind advertising)—for simple web sites. At the other extreme, hosting companies may provide their clients with full remote access to one or more full servers. These servers can then be configured to run complex applications that involve databases, sophisticated web service layers (built using tools such as ASP.NET and J2EE) and terminal services—which allow applications on a remote server to be accessed as if they were on a desktop.

The application hosting industry, which is particularly focused on these higher-level hosting activities, can be further segmented according to client size. The large business client may choose to host its own applications, may outsource to a strategic partner (also a large company) or may use a 3rd party hosting provider. Generally speaking, the first two of these options is more common in this segment.

For small and medium businesses, application hosting is dominated by large service 3rd party providers such as GoDaddy, HostGator, 1and1, etc. Competition among these providers is intense and largely based on price (see Exhibit 3 for an ad by one of the firms in the industry highlighting competition on the basis of price). However, the use of even the simplest hosting service requires some level of technical competence, which many small businesses do not possess. These businesses prefer to work with local hosting service providers who are reachable on the phone or in person and who can give them more personalized services. Many local hosting service providers collaborate with local web developers for content development. Usually such arrangements are beneficial to both the hosting service provider and the web developers because they refer clients to each other, expanding both businesses.

Support Services

The term “support services” broadly describes the activities needed to keep an organization's IT up and running. Among the most common of these are help desk (including user training), hardware and software installation, system maintenance and repair, and security related services. The market for these support services is driven by the high cost of acquiring and maintaining technical skills coupled with the low marginal costs of adding a client to an existing IT infrastructure. These economics create very high start-up costs for companies to use technology in their businesses and make them receptive to 3rd party service providers. The salary of skilled IT administrator can run into 6-digit figures. The provider of managed/monitored support services can amortize these costs over the entire client base, giving all clients a high level of expertise at a lower price-point. A typical professional services firm such as a lawyer's office or a physician's office has significant technology needs including computer help-desk support, software and hardware maintenance, and legal compliance with regulations such as HIPAA.

Hardware and Software Installation: All but the tiniest small businesses need technical expertise to set up the organization's computer infrastructure. A typical business uses centralized servers to store data, manage user accounts and provide services such as email. New users need PCs that need to be hooked up to the organization's existing infrastructure. These users also need access to the organization's

information in a secure manner. Compared to a typical home user, the problems when acquiring and updating a new PC are greatly compounded when conducted in an organizational setting. New hardware and multiple software versions can confound users. Failing to ensure that all software is properly licensed can create a serious legal risk for a small business; penalties for using unlicensed software can be harsh. Special purpose software may fail when changes to other software, particularly operating system software, is upgraded or even updated. All these challenges create a need for technical help in installing new hardware and software.

Help Desk and Training: Users typically need help in an ongoing basis when technology does not work as intended. For example, a user may experience momentary outage and need help in resolving the problem. Another user may need help in using some functionality in an application. Users often need training to use new features of updated software. Help desk support requires a great deal of personal touch. This industry includes large players like HP who vie for large corporate accounts and many local players in each market. Large corporations may have a dedicated help desk on site staffed by the service provider or the organization's own employees, while smaller businesses may call the service provider on an as-needed basis. The smaller local players depend on word of mouth and excellent customer service for business. The computer help industry is also very competitive. A Google search for "computer help services in Tampa" listed over 200 firms in the area (see Exhibit 4 for page 20 of the search results).

Of all the support services, this involves the greatest amount of end-user interaction. The human element is therefore very strong in this service.

System Maintenance and Repair: In an organization with multiple systems, it is not uncommon for individual systems to fail. Such failure can be the result of component failure, user error or external threats (such as malware). Since users are totally dependent upon IT to get their work done, any such failure immediately affects the performance of a business. There is therefore a need for quick repair of failed systems. Small businesses typically contract with service providers in advance for assured service when necessary. Generally, the arrangement calls for the service provider to arrive within a specified time window (usually 4 hours) and to bill the company at a fixed rate for work performed. Large vendors such as Dell, HP, Cisco etc also contract with these local service providers to respond to warranty calls.

Security: The need for security typically does not become readily apparent until it fails. Security failures can occur in many ways. In some cases, the failure may be environmental—a hurricane or earthquake causes the loss of critical data that has been inadequately backed up. In other cases, it may be the result of external agents, commonly called "hackers", who break into systems to steal or damage data, motivated either by financial gain or simply by malevolent intent. Most commonly, security fails as a consequence of users. Here, the causes may be even more complex—carelessness, financial gain (e.g., from data theft) or revenge motives (e.g., by a disgruntled employee or ex-employee) may all play a part.

Achieving adequate security requires a mixture of technical and organization solutions. Using standard industry practices during installation, maintenance and repair solves the majority of technical challenges in providing security. These include measures such as using good passwords and regular updates. End user training and adherence to specified processes address the majority of organizational issues. These include users never sharing passwords and avoiding macros in attachments.

Given the complexity of running an efficient and secure IT operation, a service provider such as Infinity Computer Solutions could offer very compelling value to such businesses by providing a complete package of all required IT services, including helpdesk support, data storage and application hosting at competitive prices.

Cloud Computing

A relatively new approach to IT operations was cloud computing. Cloud computing is the provision of computing as a service rather than as a product. Cloud computing makes hardware, software, and data available to users over the Internet in the same manner that a power company makes energy available over the power grid. While hosting services only provide make web applications, cloud services can be accessed directly from computer applications. An example of a cloud computing service is DropBox. To end users, their DropBox store appears no different from a remote file folder. However, the data is accessible to them from anywhere in the world. Another example is Google docs.

While components of cloud computing technologies have been around for almost a decade, it is only since the late 2000's that the services have become more competitive with desktop application suites. Providers such as Google offer businesses the option of storing all their organization's data, documents, email, calendars on remote servers and using applications such as Google docs to work on these documents. In this model, employees can even use their personal computers as their work computers, saving businesses the costs of acquiring and maintaining desktop computers.

In the early 2010's, the components of cloud computing are generally considered to be organized in a 3-layered architecture – Infrastructure as a service (IaaS), platform as a service (PaaS) and software as a service (SaaS).

Infrastructure refers to data storage and computer processing, much like hosting service providers. DropBox is an example of an IaaS service provider. Amazon offers similar services to businesses, calling it EC (elastic cloud).

Platforms refer to application development capabilities, where developers can develop applications for use by customers. Currently Google and Amazon are the best known PaaS providers.

Software refers to applications such as Google docs and Microsoft Live. This is currently an evolving model. Businesses are concerned about the protection of their data. However, analysts believe that SaaS could become more mainstream quite rapidly.

Key Technologies

The rapid growth in 3rd party hosting and IT services had been enabled by a number of key technologies. These technologies made it possible for business to cut their ties to traditional providers (such as the phone company) and to avoid the complexities of owning hardware and software. Some of the most critical of these are now described.

Co-location centers

A co-location center, sometimes also called a colo or a carrier hotel, provides equipment racks, network connectivity, cooling and electrical power to customers. Customers can use these facilities to hook up their network equipment, servers and data storage devices, generally at a lower cost than they can do themselves. Co-location centers also provide protection against disasters by maintaining state-of-the-art fire protection systems, and facilities that are designed to withstand hurricane and other natural disasters. The shared infrastructure at a co-location facility is also monitored at all times of the day by skilled technicians who monitor power levels, network connectivity and other critical elements of the shared infrastructure.

Voice-over IP

Voice-over-IP (VoIP) technology transports telephone calls over the Internet. Special VoIP phones could be plugged into Internet jacks and operate as regular phone handsets (Exhibit 5). One benefit to users of the technology is simplification: they no longer need to wire their buildings with two separate networks, one for the Internet and another for telephones. Another advantage is the capabilities of the phones. VoIP phones are in fact micro-computers and can therefore be programmed using software. For example, buttons on the phone could be programmed to link into the company's customer-relationship-management (CRM) systems, show news from sites such as CNN, or quickly lookup whether a user was present at their desk.

Integrating data and phone networks

If the phones in a physician's office are connected to the Internet, how do calls on the regular phone network reach there? After all, the phone network and the Internet are two completely independent networks. The phone network carries voice from traditional phones and the Internet carries data such as email and web pages to and from computers.

There are two popular mechanisms to integrate phone and data networks. In the first mechanism, users can designate one computer in their office as a communication server, install Asterisk on this server and add extensions hardware cards on this computer. These cards accept phone lines as inputs and connect to the computer internally (Exhibit 6). These cards convert signals between the voice and data networks. The Asterisk software on the computer can be used to configure the phone handsets in the office.

The other popular mechanism is to use an external service provider to move information between the voice and data networks. In this mechanism, incoming calls to the business terminate at the external service provider, which then forwards the calls to the business over the Internet. Likewise, outgoing calls from the business are carried over the Internet to the service provider, which then transfers them to the voice network from where the call reaches the receiver.

Hosting

During the decade between 2000 and 2010, the technologies driving web hosting had transformed what could be efficiently hosted on a remote system. The two key technologies driving this change were virtualization and remote terminal access (also called Remote Desktop service).

Virtual machines

A virtual machine (VM) is a "completely isolated guest operating system installation within your normal host operating system." The guest OS is called a virtual machine (VM) because to an end user, it appears as though it is a complete computer. A common use of VMs is in server consolidation at data centers, where different applications that were run on individual machines can be run on separate VMs on the same physical machine. By suitably selecting the applications that run on the different virtual machines, VMs can ensure that the processing capacity on the server is maximally utilized, thereby significantly lowering costs, power demand and space.

A number of vendors had created software that allowed users to create virtual machines at very low cost. One popular software was Virtual Box, offered by Sun Microsystems (now Oracle), that was available as a free download. Another popular commercial software that enabled the creation of virtual machines was called VM Ware.

Remote Desktop Services

In the traditional desktop configuration, the applications appearing on a user's display are running on the user's PC. As web-based applications become more capable, an alternative was to split the application

between the client PC (running a web browser) and the web server (which sent HTML pages to the user's PC). This type of client-server configuration requires special design and programming with the nature of the split between client and server always kept in mind.

An alternative approach to running applications on a server is to virtualize a normal PC application running on a server, as described in the previous section, and then send the display information to the client machine. Remote display of a PC application was not new—it had been popularized by Citrix in the late 1990s—but the applications of that day stretched available bandwidth. Remote terminal access, as it was then called, tended to lead to clunky performance. Thus, it was most commonly used to control applications that had a limited user interface or as a means of accessing desktop computers from field (such as the *GoToMyPC* subscription service offered by Citrix).

Combined with virtualization and the higher bandwidth offered by the Internet at the time of the case, remote terminal access evolved into remote desktop services. In principle, it became possible for companies to host all their applications on centralized PCs and to supply users with much simpler PCs. While not all applications would run properly under this configuration—software development environments, such as *Microsoft Visual Studio*, and graphic-intensive games could be a problem, for example—nearly all common business applications would. As an added benefit, such services could be displayed on different types of platforms. For example, a Mac or even a tablet might be used to display a PC application.

For Windows applications, the tipping point came when Microsoft introduced the RemoteFX feature in Service Pack 1 (SP1) of the R2 release of Windows 2008. RemoteFX allows organizations to host the entire desktop on a remote server. In particular, the graphics processing capabilities on the server could be shared among the multiple virtual machines on the server. End users access their remote desktop using any client device (laptop, PC, or other device). All applications such as MS Office and IDEs could be hosted remotely, the functionality of RemoteFX meant that clients could get responsiveness comparable to locally hosted applications. In such a setup, the organization or its users did not have to worry about installing and updating applications. All these functions could be delegated to the administrator of the remote server, on which the desktops are hosted, considerably simplifying the IT infrastructure for small-midsized businesses.

Grant Baxley

Infinity Computer Solutions (ICS) was founded by Grant Baxley. His background and experiences shaping the company had played an important role in setting up the decisions that now faced him.

Student days

Grant Baxley graduated from High School as the salutatorian of his high school class. He was deeply involved in after-school activities at high school, including being on one of the school's golf teams. For college, he chose the University of South Florida (USF) for its proximity to his home and because everything he heard about the University was positive. He graduated from USF in 2006 with an undergraduate degree in MIS from the Information Systems & Decision Sciences department in the College of Business. While USF now has a well-recognized football program, he recalls that in the days when he was at USF, he was usually one of the few USF supporters at football games. He and his family are USF football season ticket holders and his entire family continues to go to every game.

He gained work experience while at USF. Specifically, he worked at USF's Campus Recreation part time as the Web and IT administrator for the last two years at USF. Observing his manager gave me a role model on how to manage employees. In addition, the stint also introduced him to his future wife. His

years working at USF's Campus Recreation are some of his most memorable experiences at USF, and everybody worked as a team and the atmosphere was always enjoyable.

Memorable Classes:

The classes he took in the major were instrumental in getting him started in the business. Some of these included:

Database management – In the class, Grant explored the use of web-based SQL database administration using open-source tools. He found it thrilling to get the tools to actually work. He had already started web hosting before taking this class and implemented some of this technology on his live servers.

Ecommerce – He had already developed a handful of E-Commerce sites by this time. In this class, he worked with other students and opened their world to open source projects that made it all possible (shows an email he sent to students in the class offering them help and suggestions). He remembers having a guest lecturer from FiOS (Verizon's high-speed residential data service) and realizing how much fiber would change the industry.

Java – He met other entrepreneurs in this class that now are some of his closest colleagues. They have also started their own IT businesses, and though they are in similar businesses, they have all chosen to constantly share knowledge and work with each other to solve difficult problems, rather than be rivals. As appropriate, they even give work to each other.

Getting into business

Infinity Computer Solutions got its start in 2004 when Grant Baxley, the founder, while still an undergraduate student at USF, was asked by an acquaintance to develop a website for his small business selling grass seeds. After investing a considerable amount researching the various ways in which he could set up the website to meet the client's expectations. Eventually he settled on zen-cart², an open source software application to set up online shopping carts. Grant estimates that the research, development and customization of the site took him about a month and he was paid \$1,500 for the effort (he still hosts this client's website). This client introduced him to other local businesses, and soon Grant had built about 100 websites and was building a new website in hours instead of months.

Initially, Grant had used GoDaddy as a hosting service provider to host his websites. He charged his clients a fee to maintain the sites on their behalf. However, after he had built a number of sites, he decided to get into the hosting business himself, bringing all his clients to his hosting business. He started with a high-speed link and a server in the proverbial garage at his home. Later however, he realized that hardware and software installation, maintenance and repair, security and other support services were taking up too much of his time. About 2.5 years after he started his business, towards the end of 2006, he moved the server from his home to a co-location facility, Sago networks, in Tampa, Florida, where the professionals at the facility could attend to many of these issues³.

Managing initial growth

In the initial years, Sago networks served his needs for a co-location well. Eventually, he was hosting over 900 web-sites from the Sago facility. Over the years, he tried various technologies and related

² www.zen-cart.com

³ Readers may note that though Grant is an IT service provider himself, he uses the services of other IT service providers to build his own offerings

businesses. To monitor his servers and user accounts, he initially used the control panel called Helm.⁴ Later, he found a superior solution and moved to the control panel called WHMCS⁵ (Web Hosting Management Complete Solution). This control panel gave him better visibility into cash flows over coming months, and advance notification of expiring credit cards, all of which was important in running the business. For some time, he was a reseller of hosting services for a company called Host Gator⁶. HostGator was a very competitive hosting service provider, offering unlimited storage and bandwidth for less than \$10/ month. However, he stepped out of the reseller business because the margins were very low and he found better opportunities in offering more value-added services by using his specialized technical skills.

Early challenge

During the economically challenging times in late 2008-early 2009, Grant faced the most severe challenges to his business. The web development part of his business was losing money. Until then, the company had been growing and to meet client demands, he had hired three people. They all were his very best friends. However, when the business began losing money, he was forced to lay them all off. The trauma of letting his good friends go is still fresh in his mind. In fact, he has crystallized this as a business dictum, “never hire friends.”

In 2009, he stopped the web development part of his business to stem losses. While web development was bringing him new clients, it took an enormous amount of time to get the right look and feel that satisfied his clients. From September 2009 to November 2010, ran his company all by himself. Things had stabilized satisfactorily by December 2010 for him to feel comfortable hiring one person. He therefore brought in his brother in Dec 2010 as a part owner. Then in March 2011, he hired a USF student and former Best Buy Geek squad employee to a part-time position. Given his location near the University of Tampa, he solicited applications from students there as well, but without much success.

Infinity Computer Solutions

By the time of the case, Infinity Computer Solutions (ICS) had evolved into a company that provides all the IT services required by typical professional services businesses, as illustrated in Exhibit 1. While the industry was fairly competitive, Grant felt that his company provided a very attractive suite of services for small and medium sized firms who were too small to attract the attention of the large service providers. In particular, he was able to provide personal attention to clients in the local market, something the large firms could not provide at comparable costs.

ICS has been particularly successful with doctors’ offices and law firms in the Tampa Bay area. Its services include help desk support, server and PC maintenance and network installation and maintenance. In fact, it can offer most of the hosting, support and cloud services described earlier. In recent years, the firm has developed the expertise to offer IT infrastructure as a service over the cloud. This service greatly reduces IT costs for typical small and medium business clients, while also being profitable for the firm. The services and technologies supported by the firm were continuing to evolve, however, and these were, in turn, impacting his vision for the next 5 years.

⁴ <http://www.webhostautomation.com/products/helm4.aspx>

⁵ <http://www.whmcs.com/>

⁶ www.hostgator.com. Though the company is now located in Houston, TX, as the name would suggest, it had its origins in Florida, starting out in the dorm room of the company’s founder, Brent Oxley. Today, the company believes that the domains hosted by HostGator (over 5 million) make up approximately 1% of the world's Internet traffic.

Services

Infinity Computer Solutions was now offering a number of IT services. These included:

1. *Shared hosting for web sites*: This brought in steady revenue, but at very narrow margins.
2. *IT support*: Grant also offered an all-in-one IT help service at \$95/ hour purchased by clients in 12-hour blocks. These hours could be used by clients whenever needed and service would be provided within 4-hours. While this was profitable, the hours were unpredictable. There may be no client calls for months, and suddenly, all clients may call following a thunderstorm, straining the ability of his small business to serve his clients.
3. *Virtual desktop infrastructure (VDI)*: This was his flagship service for small businesses. The service provided one complete desktop per client, accessed over the Internet using remote desktop. Clients could get cloud-based document storage, applications and processing power for a fixed monthly fee per user. Many CPU-intensive clients liked the service. For example, a company designing swimming pools could access Visio and other applications over a remote desktop connection to their virtual desktop infrastructure.
4. *Monitored/ managed hosts*: For clients who prefer to host their own servers. In a monitoring arrangement, ICS monitors the servers for any problems and decides upon further action after consulting the client. Labor expenses are not included in monitoring. In a managed services arrangement, ICS monitors servers and also guarantees attending to the problem within 4 hours and devoting all the time required to deal with the issue. Industry rates in 2011 are \$125/ server/ month for monitoring and \$375/ server/ month for managing. Similar services are also available for client desktops.
5. *Advanced Hosted Services*: Other hosting services offered by ICS include voice over IP (operated through servers hosted by ICS or by the client), Virtual Servers, Remote Backup, and private clouds

These services were all profitable, and clients often needed combinations of these services. But perhaps there could be some rationalization in the services offered? For example, Grant had stopped accepting requests to develop more web sites, choosing instead to direct clients to a reliable developer he had identified. He had found over the years that these websites took up a long time (clients were always requesting to get a button placed just right, or a sentence re-worded to reflect a new corporate priority) and were not particularly profitable. Each website earned him about \$50/ year. However, he was not prepared to hand over the business of maintaining his existing clients to the developer just yet. In part, this was out of a sense of obligation because these were the clients who had helped his business get off the ground.

Technologies

As his business evolved, a number of new technologies emerged that greatly facilitated Grant's ability to meet the growing needs of his clients. Grant used all his spare time and resources to invest in learning about more value added technologies of interest to small and medium businesses. These technologies, proved to be very successful with his clients.

Architecture

In building out the e-solution site, Grant used the latest technology available. The overall architecture is shown in Exhibit 7.

The infrastructure was built around 2 Windows 2008 servers, labeled cloud 120 and cloud 121 in Exhibit 7. These servers were responsible for the entire computer processing in response to client requests.

Each of these servers had 24GB of RAM and the two servers were configured in high availability mode. This meant that in case of failure at one of the nodes, the other node would seamlessly take over the processing for both nodes. He did not want to over utilize the Processors⁷ even when operating under duress. Therefore, to make sure that the servers provided satisfactory service even when one node failed, he limited the number of clients per server to 14.

To provide storage for client data, a CTS 2600 server from LSI with 2 RAID arrays was used. One of these arrays provided high performance and the other array provided high storage. The high performance array was used as the primary storage for clients and was mapped to C:\ for clients. The high storage array provided supplementary storage and was mapped to the D:\ drive. To provide redundancy, a large storage unit is used to collect daily backups of data from C:\ and D:\.

Some of the technical features of the infrastructure included the use of SAS (serial attached SCSI) technology to connect the components and the use of high-speed disks to improve performance. SAS cables could transfer data at rates of up to 6 Gbps between two end-points. The older technology to connect devices was parallel SCSI. The primary difference between the two technologies is that SAS provided point-to-point connection between two devices whereas parallel SCSI provided a shared pipeline for all the devices. In the shared pipeline, devices often had to wait for other devices to finished sending their data before they can transmit, thus slowing down the system. With SAS, a hard disk located on another server (the CTS 2600 in this case) was accessible as quickly as if it were located within the cloud 120 and cloud 121 servers.

All the hardware in Exhibit 7 was controlled by Microsoft's Windows Server 2008 R2⁸. Grant used the HyperV features of the operating system to create virtual machines within his cloud. He generally created one virtual machine for each client. Each virtual machine was allocated a part of the 24 GB RAM available in the cloud, a part of the 1.8 TB storage available in the high performance cluster and a part of the 8TB available in the high storage cluster. For example, a typical graphics-intensive client might use 4GB RAM, 200 GB of high performance storage and 1 TB on the high storage array.

Another investment Grant made was to use high speed disks for the hard drives. Hard drives are like super-charged versions of CDs. Data is read from and written to the disks as they spin past a magnetic head. Disks that spin faster can read and write faster, leading to faster computer response times. The standard disk speeds in the market today are 7,000 RPM. For the high performance array, Grant used 15,000 RPM disks, the fastest available in the market.

To meet growing demand for his services, in 2012, Grant plans to add two more nodes to his cloud. This time, he plans to have 48GB of RAM instead of the 24GB he used previously. He also plans to use solid state drives (SSDs) instead of conventional hard disks. SSDs are new to the market and have no spinning parts. Their primary benefit is that they can provide near-instantaneous response times.

Voice-over IP

To add VoIP to his suite of offerings, Grant had acquired a Trixbox server. This appliance provided all the services of a traditional PBX, but used open-source software from the Asterisk project. The Asterisk software converts any regular computer into a communications server, allowing small and medium-sized business with some technical expertise to obtain the benefits of a PBX out of a regular PC. An appliance

⁷As the case was being written, Grant had to add two more servers to his infrastructure to manage growth, as cloud120 and cloud121 were both filled up by customers.

⁸ R2 stands for release 2. This is an update of the initial release of the software, Windows server 2008. The primary difference is that while Windows server 2008 was built on the same codebase as Windows Vista, 2008 R2 is built on the Windows 7 codebase, which is widely considered to be superior.

such as a TrixBox server eliminates the inconvenience of installing and configuring the Asterisk software, saving time and effort, which is critical for small and medium businesses such as Grant's. Trixbox only requires about 512MB of RAM. The virtualization features (hyperV) introduced by Microsoft in service pack 1 (SP1) for Windows 2008 R2 therefore enable Grant to run 48 Virtual TrixBox PBX environments within a 2U footprint server with 24GB of RAM. This makes VoIP a reasonably profitable service to offer. (see Exhibit 8 for a description of a rack unit).

Integrating data and phone networks

Grant had chosen to use an external service provider to move information between the voice and data networks, with *bandwidth.com* as the carrier. The company gave him very competitive rates, which were just a fraction of traditional phone rates. This helped his business grow and attract a sizeable number of small businesses in the area. However, of late, Sago was experiencing unpredictable network outages. This was hurting his ability to provide his customers with the quality of service he believed they deserved. For example, in early 2011, he had an outage that spanned 2 days totaling 6 hours⁹. It was unacceptable for a physician's office to be without phone service for 30 minutes. A search for an alternate colo led him to e-solutions¹⁰, another service provider in Tampa. Grant promptly began moving his high-value clients to the e-solutions site in December 2010. By March 2011, he had moved all his high-value clients to the new data center. While his shared hosting (web site) clients were still being served from Sago networks, he was moving them over as quickly as he could in his spare time. Between the two service providers, he had 198 IP addresses (128 at e-solutions and 70 at Sago networks).

His newest offering was infrastructure as a service, also called the virtual desktop. The release of Windows Server 2008 R2 had enabled this business.

Hosting

A number of Baxley's legacy clients had not been migrated to ICS's new architecture. The ongoing outages at Sago, where he hosted these shared hosts, were becoming a concern, however. He found himself worrying frequently about his options. He estimated it would take him about 90 days to move the shared clients to the e-solutions facility. Given the low margins in this segment of his business, he was unable to justify giving this task high priority. He had also considered creating a simple tool that would allow his clients to move their hosting service to the new e-solutions facility on their own. But he was not sure how many of his clients would be comfortable using the tool. There was also the matter of a commitment he had made to his clients all the time he had been in business – that a differentiator of his company over competitors such as HostGator was his customer service. His clients knew they could call him anytime with any question about their sites. His clients were used to the hand-holding he had always provided and he was not willing to back down from that commitment.

To deal with the complexities of the existing arrangement, he had also occasionally toyed with the idea of handing his shared hosting clients to another local reseller of hosting services. This person might provide the necessary hand-holding to these clients, while freeing up Grant to focus on building his business.

5 year vision

As he looked ahead towards the next 5 years, Grant saw himself positioning his company as a guide to other small to medium sized businesses on utilizing the latest technology to increase efficiencies and reduce costs. His strength was his local presence. In his experience, his clients were often needy. It was not unusual for a client to ask for help in changing their telephone greeting for the holiday season.

⁹ The outage was caused by the failure of a switch that had no back-ups. Fortunately, Grant was able to failover to the e-Solutions Data Center or forward phone numbers if necessary.

¹⁰ <http://esnet.com/>

Although Grant Baxley appreciated the recurring, predictable and low-maintenance revenues that the business currently generated, he recognized the IT world was constantly changing. He therefore concluded that he needed to evolve, and perhaps rethink his business model, while—at the same time—ensuring that his current customers were not alienated. This meant that he would need to make some challenging decisions, and place some strategic bets on how the technology world would reshape itself. Services such as the Amazon cloud and the Google cloud were gaining traction. In response to specific client requests, he had configured some services on the Amazon cloud. For the moment (2011), he found that he could offer clients a lower price point by operating his own infrastructure than by using Amazon IaaS service.

Current Issues

ICS has proven a highly successful business during what had been trying economic times. Nevertheless, Baxley found himself facing a number of issues that would soon require decisions on his part. These issues included both technology and management elements.

Predictability

In building out his business, Grant had come to realize the importance of predictability in all aspects of his business. This included his time and the time of his employees. There was also the business issue of a predictable revenue stream these clients generated for his business. He was finding that many of his plans were being disrupted by clients of his IT support service claiming all their anticipated hours for the year within a one-week period. He was therefore considering a monthly service plan offering up to 10 hours per month at \$375/ month. Another option he considered was to offer managing or monitoring servers at a fixed cost per server. This latter option seemed to be popular with his clients. His idea was that he would have a more reliable estimate of the availability of the people in the company (including himself) for service expansion and business development. His existing clients would be allowed to continue with their existing plans, but future clients would not be offered an annual bucket of hours.

Perhaps there were other ways to add predictability to the business?

Marketing

Over the past year, Grant had refined his VoIP offering and created awareness in the Tampa market for his prowess at offering the service reliably and at low costs. This service was being marketed under the TeleVoIP brand. Now that he had perfected his offering, and with 12 clients, the service had grown beyond the proof-of-concept stage, he was looking for ways to expand the TeleVoIP brand. He therefore needed to get greater clarity on the core elements of his marketing plan.

Branding

Simultaneously, to target the small-business market, including professional establishments such as physicians and lawyers, he had begun promoting his small-business-IT-service brand – Solutions by ICS¹¹ (see Exhibit 8 for the home page of the web site). This effort was bringing him opportunities to pitch his services to bigger clients than those he currently served. He was beginning to see some success in this space, including among businesses with 100+ employees. With this development, he had begun offering to build private clouds onsite for them – basically building out for the companies, what he had built in the datacenter for his own business (Exhibit 7).

¹¹ <http://www.solutionsbyics.com/>

Location

As the array of services offered by Grant grew, he found that clients increasingly wanted to visit his facilities to assure themselves of his financial and technical strength. However, since the founding of his company, he had operated out of inexpensive office space near Downtown Tampa. The facility was utilitarian and well-located, but not inviting to bring clients over. He mulled whether the additional costs of operating out of a nicer facility would outweigh any benefits from the move.

Hiring

Now that the business had stabilized, and Grant wanted to focus more of his time and energy into marketing the new services, he was looking to hire two people. One of these hires would be responsible for all day-to-day operations of the company, including such mundane activities such as obtaining new credit card information for expiring credit cards, ensuring that all regular payments were made on time, handling routing service calls from clients etc. He called this person an “office manager” and was considering placing an ad for this position on Craigslist.

The second hire was going to be a technical person, someone who could understand a client’s technical needs and design solutions to meet these needs. This person could be a face of the company, much like Grant himself. Grant called this position a “technical consultant”.

Of these issues, the personnel issue was, perhaps, the most pressing. His ability to move the business forward depended heavily on his time. At the moment, he barely had enough time in the day to deal with routine activities. If he was going to give strategy the time it deserved, he would need help. The problem was: What kind of help?

He felt that a number of avenues were open to him:

1. *Hire a recruiting agency to select professionals he could hire:* This option would occupy the least amount of his time and would doubtless yield a high quality applicant pool. The questions it raised were: a) Would it be worth the cost of retaining such an agency (typically 3 months of salary for the individual hired)? and b) Could the company afford the \$40,000 to \$60,000 salary such an individual would normally command?
2. *Canvass his network of contacts to identify professionals he could hire:* This would reduce the recruiting cost but would leave the salary issue unchanged. The other question raised is would such a top-quality professional view ICS as a long term career choice? If not, would Baxley soon be required to repeat the whole exercise?
3. *Post job ads on career on inexpensive or free sites such as Craig’s List:* This would demand that Baxley take full responsibility for screening and hiring—a great deal of effort in an area where he did not have a great deal of experience. Where would he find the time?
4. *Hire a retiree and train him/ her to perform routine work and simple technical maintenance:* This would free up some of his time, and might not be too expensive. On the other hand, did he want to train someone who would likely be leaving soon and who might therefore have limited motivation to continue developing his or her skills as technologies evolved?
5. *Hire a student and train him/ her in routine office work:* Probably the cheapest solution, but the one with the greatest risk that Baxley’s time would be totally drained by the training process and that errors that might impact clients would be made. Baxley also wondered if he could offer any type of a career path to that individual.
6. *Continue as before, just work harder until the company had acquired a medium sized-long term client, assuring a steady cash flow, and then look for new hires:* Although the option might be the safest in the short term, it was becoming increasingly difficult to find the time to locate such a client.

Naturally, the technology, marketing and hiring decisions could not be made independently of each other. But whatever decisions he made, it would be better if they were made sooner rather than later.

Exhibit 1: Class email (06/28/06)

Hey Guys,

If any one is having problems with building their website for the E commerce class, I run a web hosting business and can help you with installing mambo joomla zen cart or any other content management system. My web site is <http://www.infinityhosting.net> all you will need is the basic plan, and you will need to register a domain name from here: <http://domains.infinitycomputersolutions.net> if you respond to this email, please email me at

ics@infinitycomputersolutions.net or grantbaxley@gmail.com an example of an online store I have done and is hosted on our servers is: <http://www.hancockseed.com> an example of a content management system i have setup is: <http://www.tnty.org/>

if you have any questions you can call me at 813.787.6587

Exhibit 2: Host infinity web page

The screenshot displays the Host Infinity website interface. At the top, the phone number 1.888.287.9198 and the date Saturday, 22 October 2011 are visible. The Host Infinity logo is prominently featured. A navigation menu includes Home, Web Design, Web Hosting, Domain Registration, Business Solutions, Support, Our Company, and Contact Us. A 'Web Hosting Control Panel Login' section contains fields for Username and Password, along with a 'Login' button and links for 'Forgot Password?' and 'Need an Account?'. The main content area is divided into several sections: 'AWARDS' featuring a 'TOP PICK HOST 2008' badge; 'INFINITY SERVICES' with an 'EXCHANGE LOGIN' button; 'PROFESSIONAL PLAN' priced at \$9.95, listing features like 100 GB Disk Space, 4,000 GB Bandwidth Transfer, 25 MySQL Databases, 1,000 E-Mail Accounts, 99.9% Uptime Guarantee, 5 Hosted Domains, Windows Based Hosting, Helm Control Panel, and Web Based Email; 'CORPORATE PLAN' priced at \$19.95, listing features like 200 GB Disk Space, 2,000 GB Bandwidth Transfer, 50 MySQL Databases, 2,000 E-Mail Accounts, 99.9% Uptime Guarantee, 10 Hosted Domains, Windows Based Hosting, Helm Control Panel, and Web Based Email; 'OUR CLIENTS' with a testimonial from Humberto; and 'CLIENT TESTIMONIALS' with a testimonial from Charlotte Tomkow. A 'Why Choose Us' section highlights the company's services and 100% customer satisfaction. Other sections include 'Professional Web Development', 'Web Hosting Services', and 'Computer Repair Services'. The footer contains contact information: 813 W. Platt St. | Tampa, Florida 33606 | 888.287.9198 | 813.319.3704 | Fax: 813.319.2864, and copyright notice: © 2005 - 2007 Infinity Computer Solutions | All rights reserved.

Exhibit 3: Print ad for hosting services (Network World, Oct 2011)

WHY PAY MORE FOR .COM?

--- HURRY! OFFER ENDS 10/31/2011 --- HURRY! OFFER ENDS 10/31/2011 --- HURRY! OFFER ENDS 10/31/2011 ---

	1&1	GoDaddy®	Network Solutions®
.com	\$9.99	\$11.99	\$34.99
ICANN Fee	Included	\$0.18	Included
Private Domain Registration	FREE!	\$9.99	\$9.99
Annual Cost	\$0.99* first year, then \$9.99	\$22.16	\$44.98

BEST VALUE!

YOUR PRIVACY IS IMPORTANT. WE AGREE.

That's why at 1&1, all domains come with FREE Private Domain Registration to protect your name, address, phone number and e-mail from spammers and identity thieves.

1&1

MEMBER OF **united internet**

Get started today, call **1-877-461-2631** www.1and1.com

* \$0.99 special offer is valid through 10/31/2011. Price is valid for the first year only. After first year, standard pricing applies. Private domain registration is not available for .us, .co, and .ca domains. Visit www.1and1.com for full promotional offer details. Program and pricing specifications and availability subject to change without notice. 1&1 and the 1&1 logo are trademarks of 1&1 Internet AG, all other trademarks are the property of their respective owners. © 2011 1&1 Internet AG. All rights reserved.

Exhibit 4: Google search for computer help services in Tampa

+Manish **Web** Images Videos Maps News Gmail More ▾

 computer help services in tampa  Advanced search

Search Page 20 of about 280,000,000 results (0.32 seconds)

Everything

Images

Maps

Videos

News

Shopping

More

Tampa, FL

Change location

All results

Related searches

More search tools

Tampa Computer Repair - Free 10-Minute Diagnostic Ad
www.citruscomputers.com
Call (813) 926-9672 today!
[Show map of 7512 Ehrlich Road, Tampa, FL and nearby citruscomputers.com locations](#)

Tampa Bay Data Recovery for Servers Computer Notebook Laptops
tampabaycomputerservice.com/data-recovery.htm
Computer Service and Repair for Tampa Bay Business. Network **Support for Tampa Bay Business.** Website **Service,** Design, Hosting, Marketing for **Tampa Bay ...**

Mighty Micro Computer Repair Service Largo Seminole ...
www.mitymicro.com/who.htm
On-Site Pinellas County **Computer Services** Seminole In-Home **PC Repair Largo ...** in 1981, known today as **Mighty Micro Computer Service** offering **Tampa Bay ...**

Tampa Dell Computer Repair Service Center & Laptop Notebook ...
www.baybusinessedge.com/tampa-dell-repair.htm
We can **repair** any type of Dell **computer,** laptop / notebook here in **Tampa, FL.** We offer competitive rates and guaranteed **service.** We can fix any model Dell ...

The IT Guys Inc - Computer Repair Tampa Florida, PC Repair ...
www.theitguysinc.com/computer_repair_tampa.html
The IT Guys Inc - **Computer Repair Tampa Florida** and **Computer Service** to Business & Residential Customers - 25% Off First **Service.**

PSG, Inc. - Contract Computer Network Services, Saint Petersburg ...
psglink.com/computerservices.html
Computer Repair, Malware-Spyware-Virus Removal, Onsite and Remote **Support - St Petersburg, Tampa Bay, Clearwater, Florida, ...** When you need onsite **computer service** in your office or home, we can take care of your needs quickly and ...

Discount Computer Store Tampa Repair Sales Parts Upgrades ...
www.directron.com Policies | Feedback
Online **Computer Store** Serving **Tampa** Customers. Order online ... We ship nationwide including **Tampa, ...** Shipping Policy, Customer **Service,** Payment Policy ...

Tampa Computer Networking Sales Service Repair
www.tampacomputernetworkingsalesrepair.com/
Tampa Computer Networking, Sales, **Service & Repair** offers a variety of **services** such as repairs, upgrades, troubleshooting, new/used **computer** sales, **service ...**

Design Masters Net Services Tampa Web Site Design Clients
www.dmasters.net/web-clients.htm
TampaTechs.com **Computer** and Technology Services. **TampaTechs.com** - Provides onsite **computer repair service** to **Tampa Bay** and surrounding areas ...

Computer Service - CHEAPEST IN TOWN! (St. Petersburg, FL ...
florida.inetgiant.com Services Tech Help Computer Consultants
Call Now (727)510-6017 to schedule a **SERVICE AND REPAIR** appointment! My name is Blake and - **Services - Computer-Consultants - Tampa.**

Home Services - Computer Repair - Tampa Computer Doctors ...
www.tampafastrepair.com/home_services.php
With our home **services** for your home or business, **Computer Doctors** can diagnose and fix most problems within 1 visit!

Searches related to **computer help services in tampa**
[friendly computer services tampa](#) [amazing computer repair services tampa fl](#)
[tampa laptop service and repair](#) [office pc support tampa fl](#)
[computer repair center tampa fl](#) [asap computer repair service tampa fl](#)



[Previous](#) 10 11 12 13 14 15 16 17 18 19 20 21 22 23 24 25 26 27 28 29 [Next](#)

[Search Help](#) [Give us feedback](#)

[Google Home](#) [Advertising Programs](#) [Business Solutions](#) [Privacy](#) [About Google](#)

Exhibit 5: Voice over IP phone (courtesy: Aastra)



Exhibit 6: PC telephony card (courtesy: Digium)

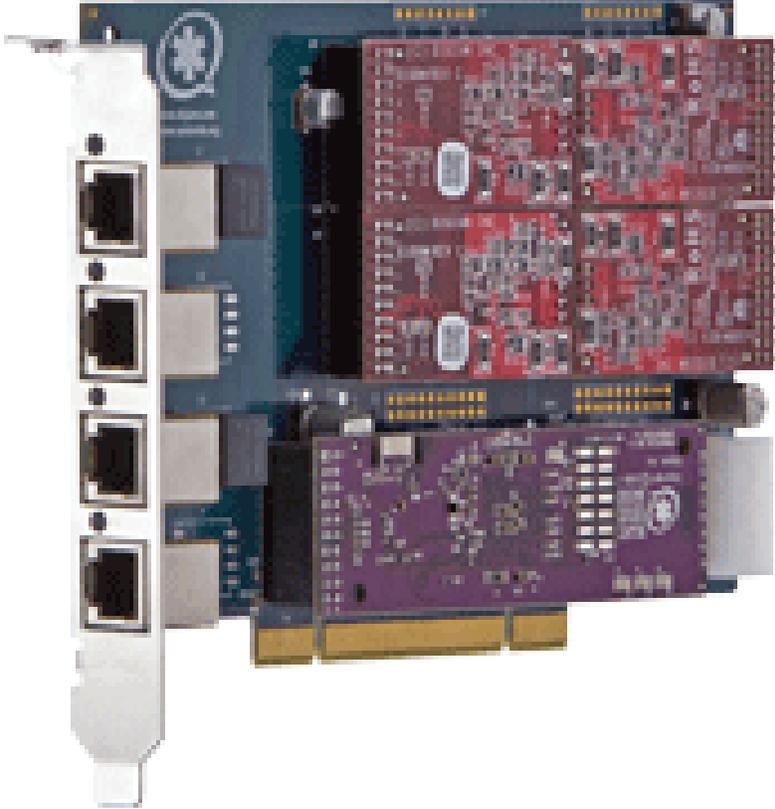

Exhibit 7: Virtual desktop infrastructure at Infinity Computer Services

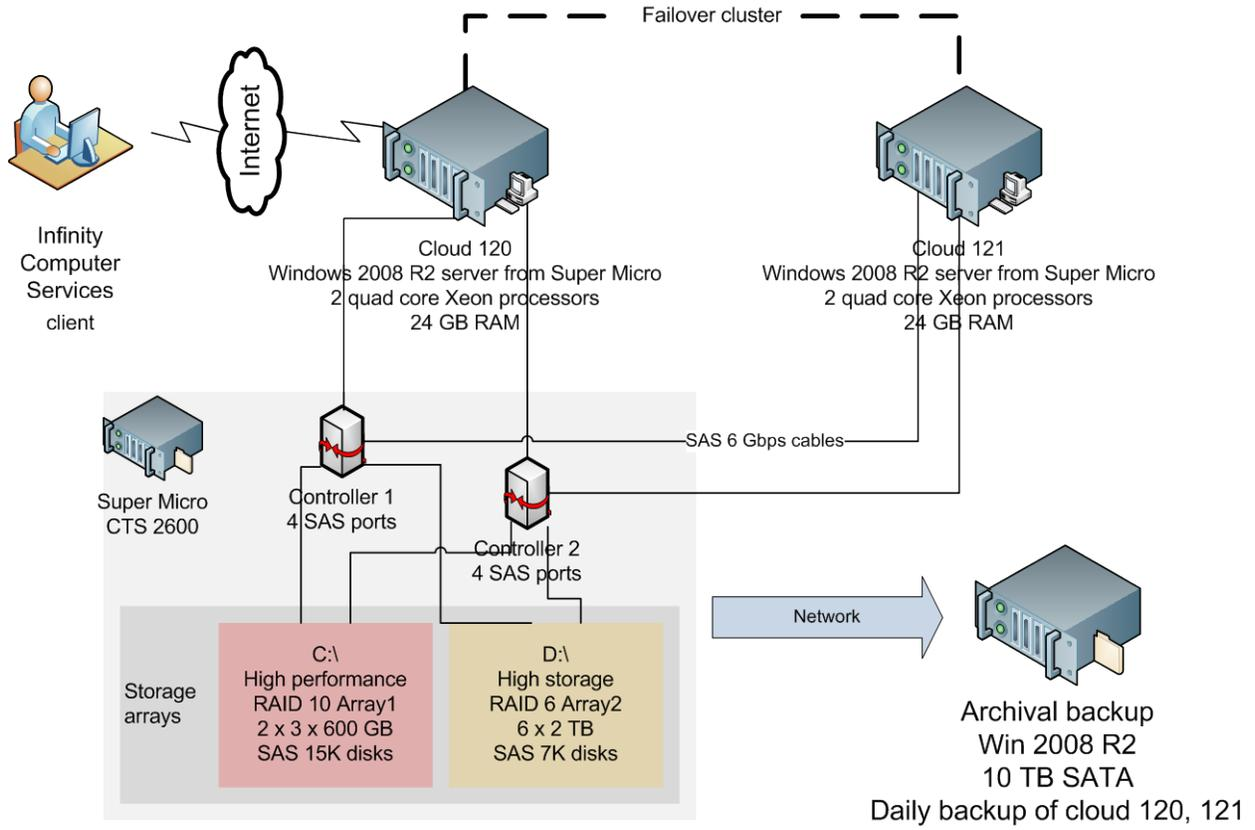

Exhibit 8: Rack units or U¹²

Computer hardware is typically mounted on racks for safe and firm handling. For example, the figures below show how Grant has mounted his hardware in the data center at e-solutions. To ensure that racks and hardware can be interchanged, the industry has agreed on standard heights and widths for equipment. The standard widths are 19 inches and 23 inches. The standard height is 1.75 inches. This height is referred to as 1U. The smallest equipment is therefore 1.75 inches in height. Bigger units can be 2U in height (3.75 inches). 2U and 4U equipment is quite common in the industry.



¹² Some information in this exhibit is taken from Wikipedia

Exhibit 9: Solutions by ICS web page

The screenshot shows the ICS website with a dark grey header and a blue vertical-striped banner. The ICS logo is on the left, and the company name 'INFINITY COMPUTER SOLUTIONS' is in the center. A 'Quick Links' dropdown menu is on the right. Below the banner is a navigation menu with links: Home, IT Consulting, Services, Get a Quote, Testimonials, About ICS, Contact Us, and Site Map. A photo of a woman is on the left side of the banner. To her right is the 'Web Development Services' section with two columns of bulleted items: Content Management Systems, E-Commerce, Web Based CRM, Custom Web Applications, Community Based Designs, and Streaming Web Media. Below the banner is a breadcrumb trail: 'You are here: Home'. On the left is a 'Newsletter' sign-up form with fields for Name and E-mail, and buttons for 'Subscribe', 'Unsubscribe', and 'Go!'. The main content area is titled 'IT business Solutions' and contains a paragraph about the company's services, a list of services, and contact information. The services list includes: Server Installation, IT Consulting, CRM and ERP Implementation, Content Management Systems, E-Commerce, Exchange Server Migration/Deployment, BlackBerry Enterprise Server Installation, VOIP Phone Systems Integration, Shared and Dedicated Web Hosting, Search Engine Optimization, Remote Backup Servers, Custom Web Development, Dentrax G2, G3 Installation, Devix Integration for Digital Imaging, Server Virtualization, San Deployment, Fiber Optic Cabling and Network Deployment, Sage: Act, TimeSlips Installation, Migration to Client Profiles for Lawyers, E-Marketing Services, Graphics and Web Design, and Exchange Hosting. Contact information includes: Toll Free: 1.888.287.9198, Local: 813.319.3704, Fax: 813.319.2864, and Email: ICS@HostInfinity.com. A '[Back]' link is at the bottom of the main content area. The footer contains copyright information and a repeat of the navigation menu.

Quick Links

ICS INFINITY COMPUTER SOLUTIONS
INFINITE POSSIBILITIES. INFINITE SOLUTIONS

Click Here to Request a FREE IT Audit

Home IT Consulting Services Get a Quote Testimonials About ICS Contact Us Site Map

Web Development Services:

- Content Management Systems
- E-Commerce
- Web Based CRM
- Custom Web Applications
- Community Based Designs
- Streaming Web Media

You are here: Home

Newsletter

Receive Technology updates and offerings:

Name

E-mail

Subscribe

Unsubscribe

IT business Solutions

Infinity Computer Solutions Aims to provide the complete IT solution for growing companies.

We are proud to announce a broad service area covering The Greater Tampa Bay area. We provide IT, web, consulting, and computer services to local small to medium sized businesses. We find cost effective solutions for your IT needs. Please review our map and the services we offer below:

Our Services:

- Server Installation
- IT Consulting
- CRM and ERP Implementation
- Content Management Systems
- E-Commerce
- Exchange Server Migration/Deployment
- Blackberry Enterprise Server Installation
- VOIP Phone Systems Integration
- Shared and Dedicated Web Hosting
- Search Engine Optimization
- Remote Backup Servers
- Custom Web Development
- Dentrax G2, G3 Installation
- Devix Integration for Digital Imaging
- Server Virtualization
- San Deployment
- Fiber Optic Cabling and Network Deployment
- Sage: Act, TimeSlips Installation
- Migration to Client Profiles for Lawyers
- E-Marketing Services
- Graphics and Web Design
- Exchange Hosting

Contact us today for a quote on your IT needs:

Toll Free: 1.888.287.9198
Local: 813.319.3704
Fax: 813.319.2864
Email: ICS@HostInfinity.com

[Back]

Copyright © 2005 - 2011 Tampa Florida. Infinite Possibilities, Infinite Solutions

Home IT Consulting Services Get a Quote Our Portfolio About ICS Contact Us
813 W. Platt St. | Tampa, Florida 33606 | 888.287.9198 | 813.319.3704 | Fax: 813.319.2864